

3x2 Pop-Up System (Curved Specification)



Our preferred format for receiving artwork is as high resolution PDF file with all fonts embedded. If you are unable to supply a PDF please look at the Supplying Files on our website.

We suggest that artwork is originated at quarter size - see details below for size specifications

In order to produce an acceptable halftone result on the final output it is recommended that any pictures (bitmaps, jpg, tif etc.) are **at least 150dpi at finished size**. Therefore if you are working at **quarter size any pictures should be 600dpi**. Failure to observe this rule could lead to disappointing results.

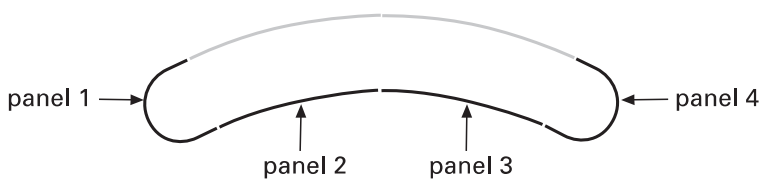
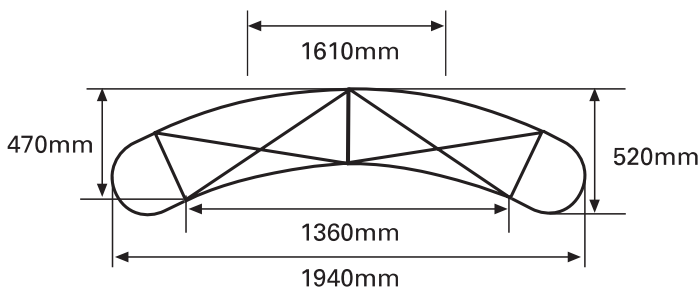
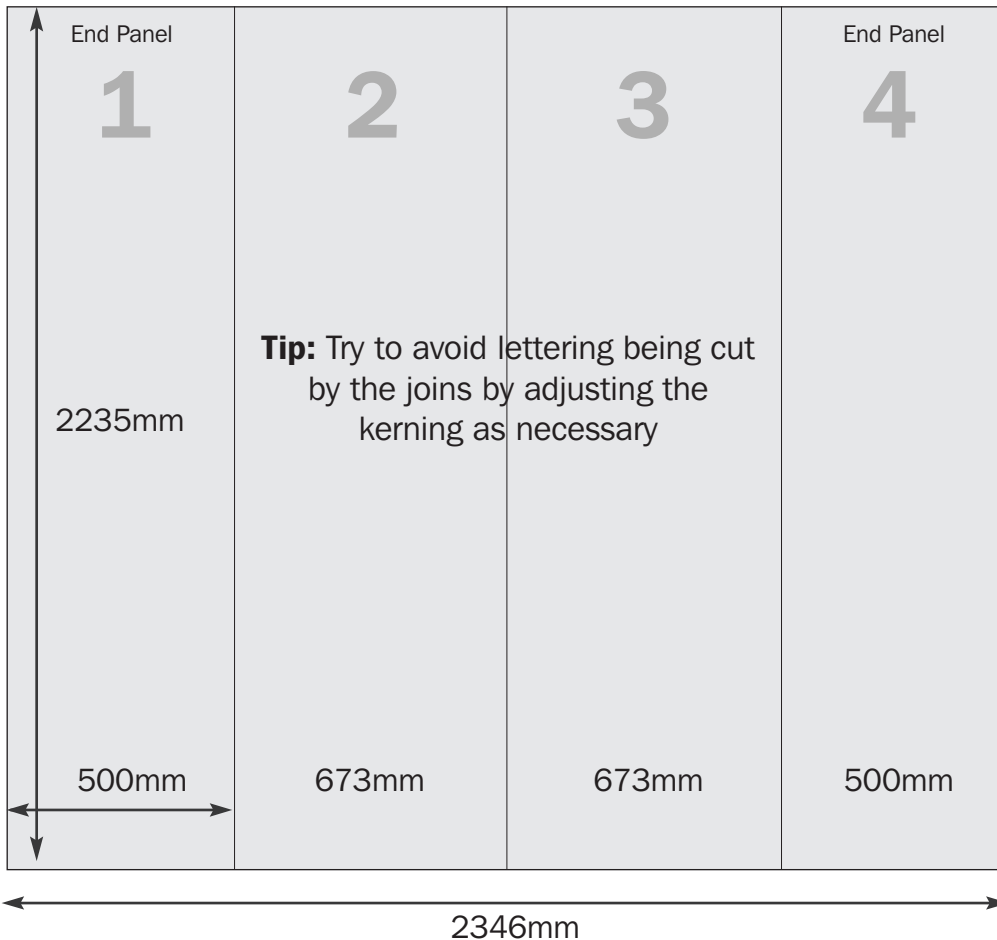

3x2 Graphic Dimensions

Overall artwork size:

2235 x 2346mm

All images **150dpi at finished size**

Quarter size document:

558.75 x 586.5mm

All images **600dpi at quarter size**

Rear graphics panel widths (if required)

For sets which are being covered on both sides of a curved set the rear central panels (2 & 3 on the diagram above should each measure 812mm in width. They are widened to account for the wider radius.

offsite digital

Unit 5, Bolding Hatch Farm Business Centre
Bishops Stortford Road, Roxwell, Chelmsford, Essex CM1 4LF

Telephone: +44 (0)1245 231900 Facsimile: +44 (0)1245 231911
email: sales@offsitigroup.net www.offsite.digital.co.uk

3x3 Pop-Up System (Curved Specification)



Our preferred format for receiving artwork is as high resolution PDF file with all fonts embedded. If you are unable to supply a PDF please look at the Supplying Files on our website.

We suggest that artwork is originated at quarter size - see details below for size specifications

In order to produce an acceptable halftone result on the final output it is recommended that any pictures (bitmaps, jpg, tif etc.) are **at least 150dpi at finished size**. Therefore if you are working at **quarter size any pictures should be 600dpi**. Failure to observe this rule could lead to disappointing results.

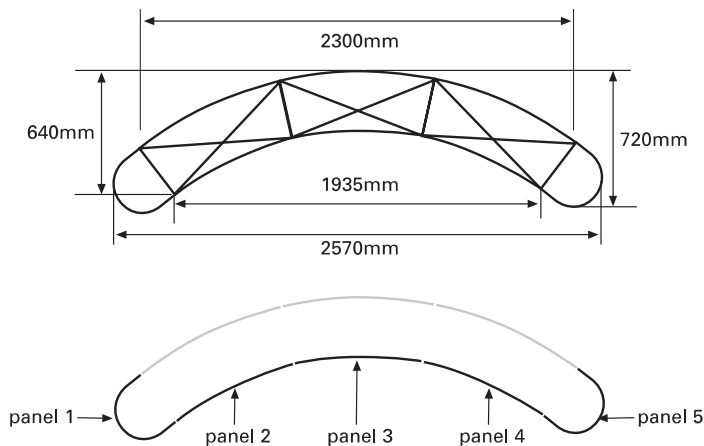
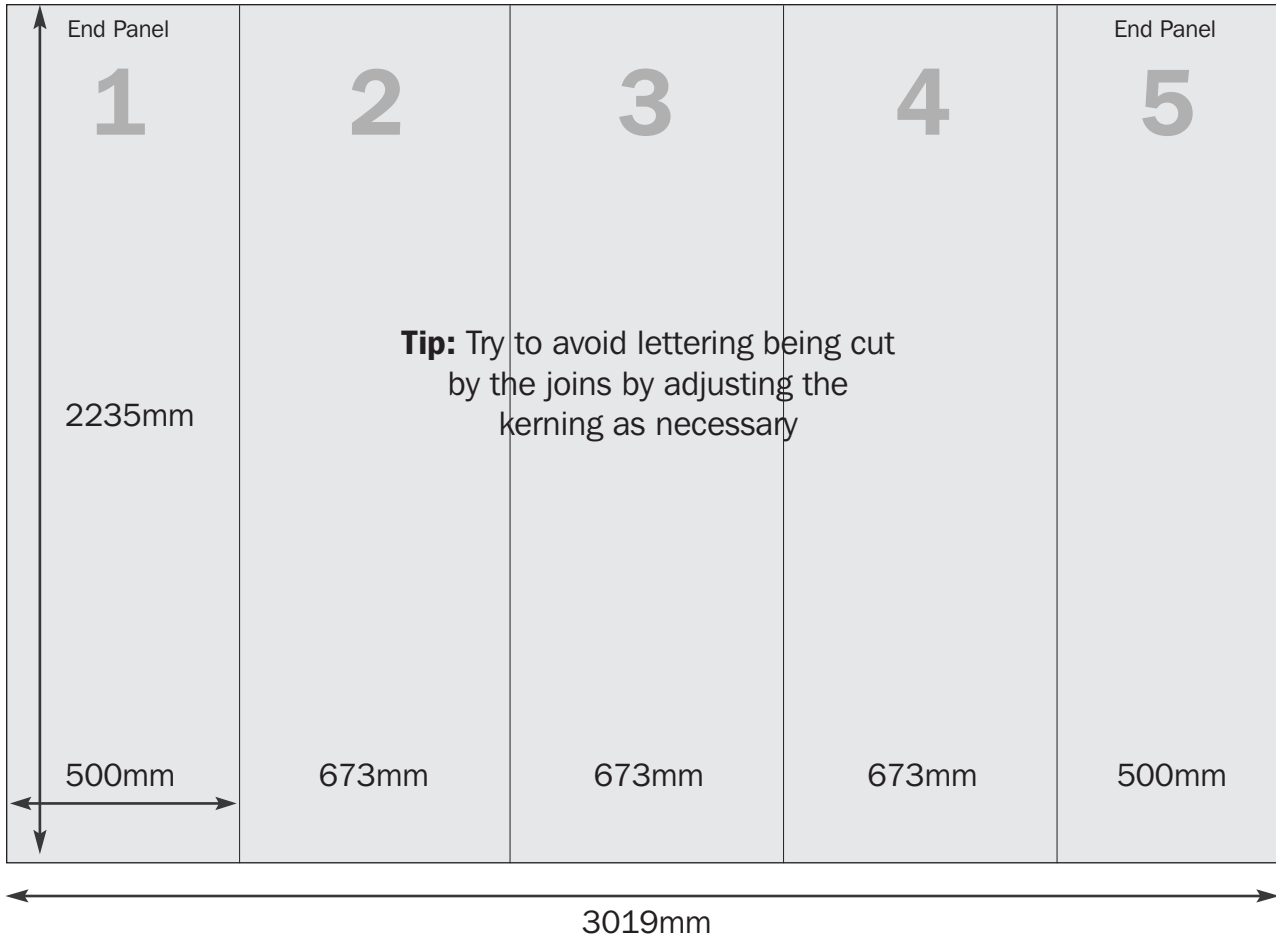

3x3 Graphic Dimensions

Overall artwork size:

2235 x 3019mm

All images **150dpi at finished size**

Quarter size document:

558.75 x 754.75mm

All images **600dpi at quarter size**

Rear graphics panel widths (if required)

For sets which are being covered on both sides of a curved set the rear central panels (2, 3 & 4 on the diagram above should each measure 812mm in width. They are widened to account for the wider radius.

offsite digital

Unit 5, Bolding Hatch Farm Business Centre
Bishops Stortford Road, Roxwell, Chelmsford, Essex CM1 4LF

Telephone: +44 (0)1245 231900 Facsimile: +44 (0)1245 231911
email: sales@offsitigroup.net www.offsite.digital.co.uk

3x4 Pop-Up System (Curved Specification)



Our preferred format for receiving artwork is as high resolution PDF file with all fonts embedded. If you are unable to supply a PDF please look at the Supplying Files on our website.

We suggest that artwork is originated at quarter size - see details below for size specifications

In order to produce an acceptable halftone result on the final output it is recommended that any pictures (bitmaps, jpg, tif etc.) are **at least 150dpi at finished size**. Therefore if you are working at **quarter size any pictures should be 600dpi**. Failure to observe this rule could lead to disappointing results.

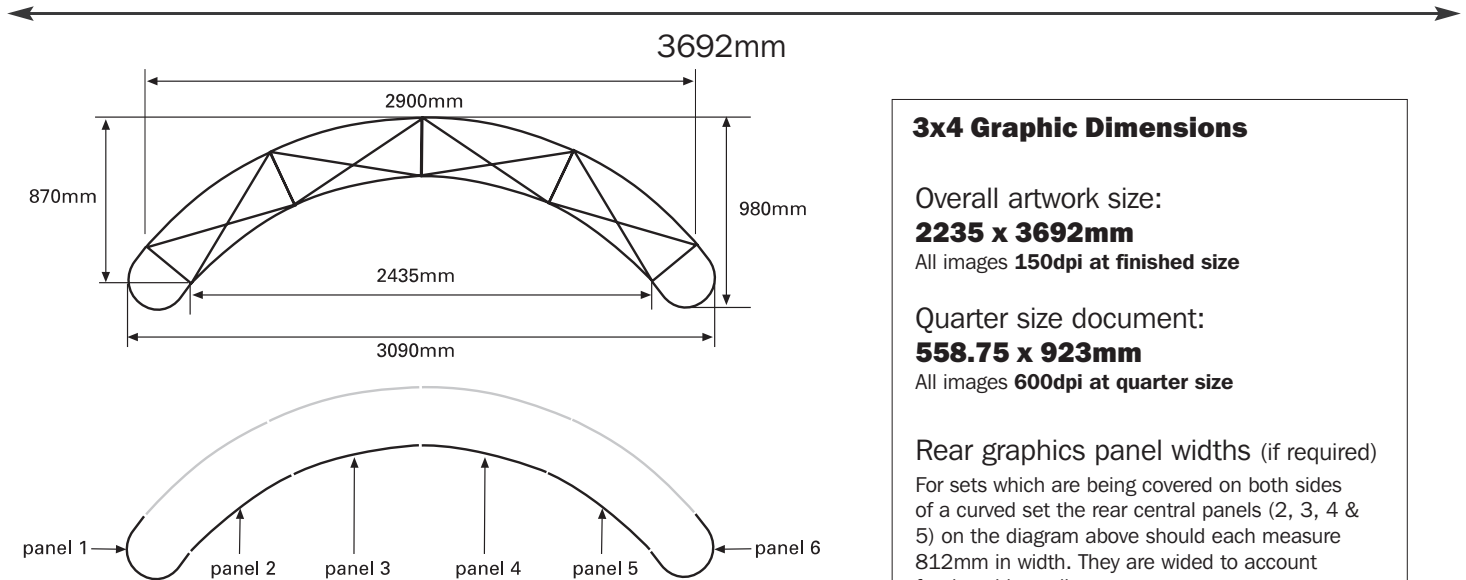
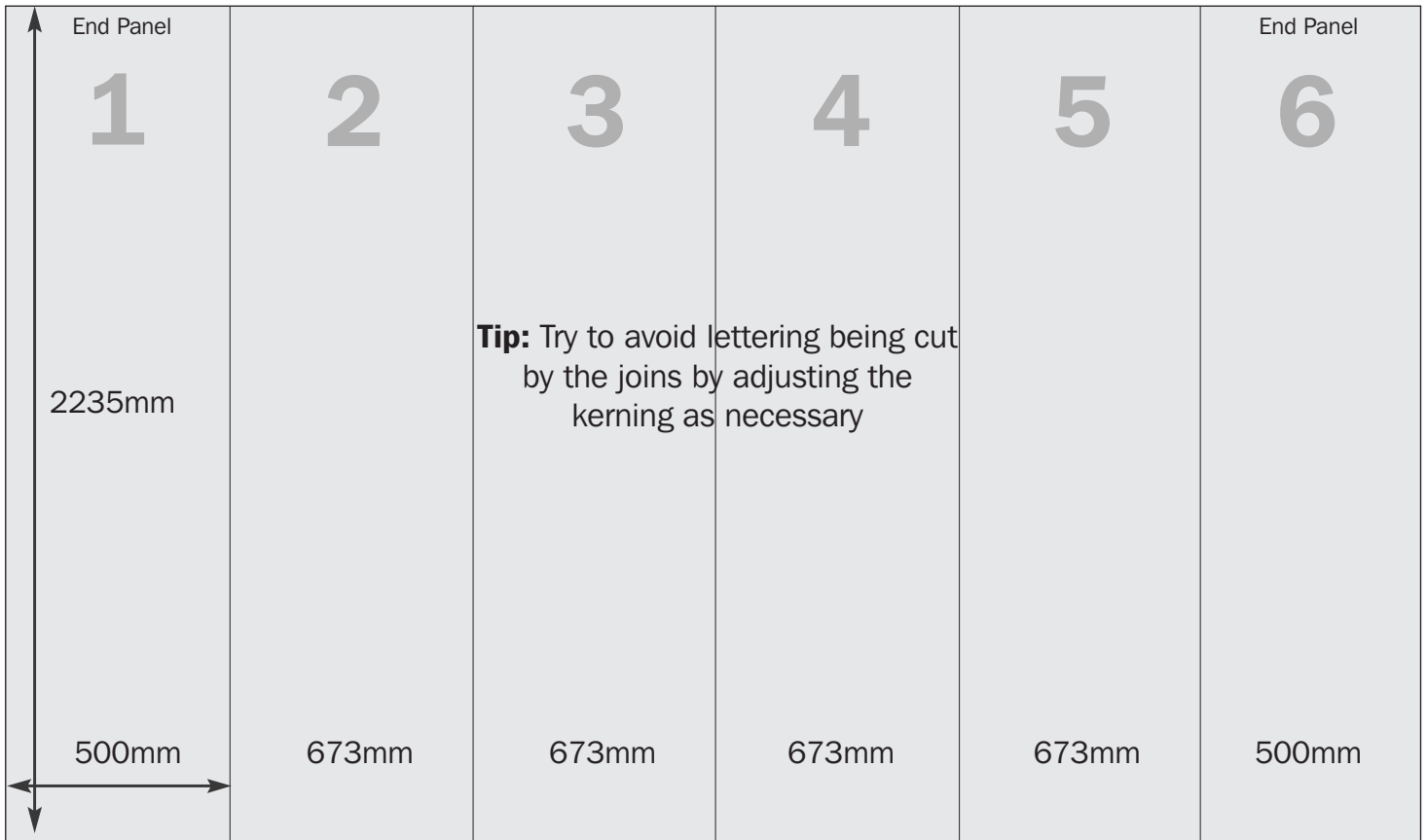

3x4 Graphic Dimensions

Overall artwork size:
2235 x 3692mm
 All images **150dpi at finished size**

Quarter size document:
558.75 x 923mm
 All images **600dpi at quarter size**

Rear graphics panel widths (if required)
 For sets which are being covered on both sides of a curved set the rear central panels (2, 3, 4 & 5) on the diagram above should each measure 812mm in width. They are widened to account for the wider radius.



Unit 5, Bolding Hatch Farm Business Centre
 Bishops Stortford Road, Roxwell, Chelmsford, Essex CM1 4LF

Telephone: +44 (0)1245 231900 Facsimile: +44 (0)1245 231911
 email: sales@offsit egroup.net www.offsit edigital.co.uk

3x5 Pop-Up System (Curved Specification)



Our preferred format for receiving artwork is as high resolution PDF file with all fonts embedded. If you are unable to supply a PDF please look at the Supplying Files on our website.

We suggest that artwork is originated at quarter size - see details below for size specifications

In order to produce an acceptable halftone result on the final output it is recommended that any pictures (bitmaps, jpg, tif etc.) are **at least 150dpi at finished size**. Therefore if you are working at **quarter size any pictures should be 600dpi**. Failure to observe this rule could lead to disappointing results.

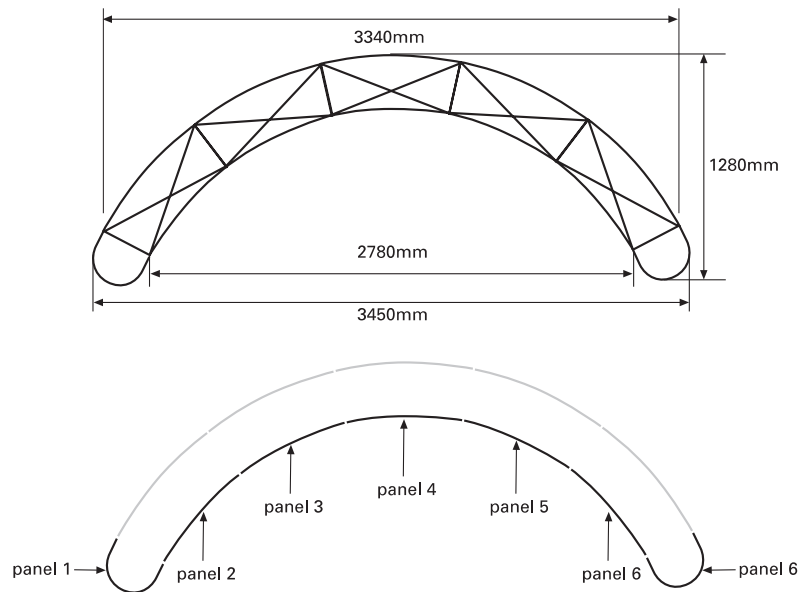
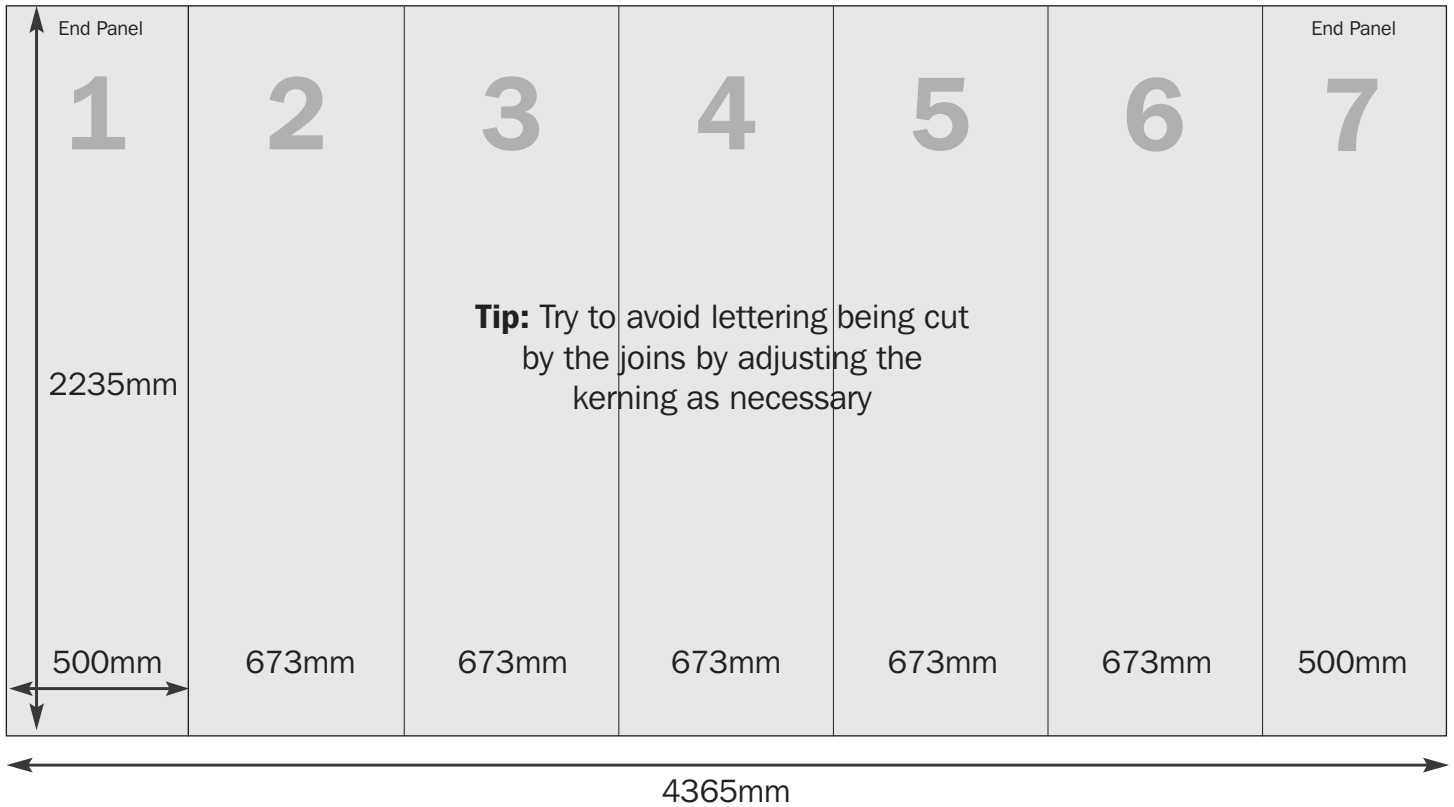

3x5 Graphic Dimensions

Overall artwork size:
2235 x 4365mm
 All images **150dpi at finished size**

Quarter size document:
558.75 x 1091.25mm
 All images **600dpi at quarter size**

Rear graphics panel widths (if required)
 For sets which are being covered on both sides of a curved set the rear central panels (2, 3, 4 5 & 6) on the diagram above should each measure 812mm in width. They are widened to account for the wider radius.



Unit 5, Bolding Hatch Farm Business Centre
 Bishops Stortford Road, Roxwell, Chelmsford, Essex CM1 4LF

Telephone: +44 (0)1245 231900 Facsimile: +44 (0)1245 231911
 email: sales@offsitigroup.net www.offsite.digital.co.uk

3x2 Pop-Up System (Straight Specification)



Our preferred format for receiving artwork is as high resolution PDF file with all fonts embedded. If you are unable to supply a PDF please look at the Supplying Files on our website.

We suggest that artwork is originated at quarter size - see details below for size specifications

In order to produce an acceptable halftone result on the final output it is recommended that any pictures (bitmaps, jpg, tif etc.) are **at least 150dpi at finished size**. Therefore if you are working at **quarter size any pictures should be 600dpi**. Failure to observe this rule could lead to disappointing results.

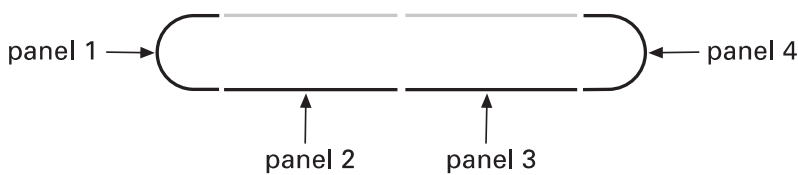
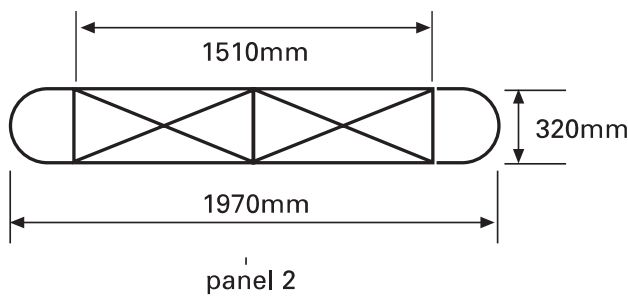
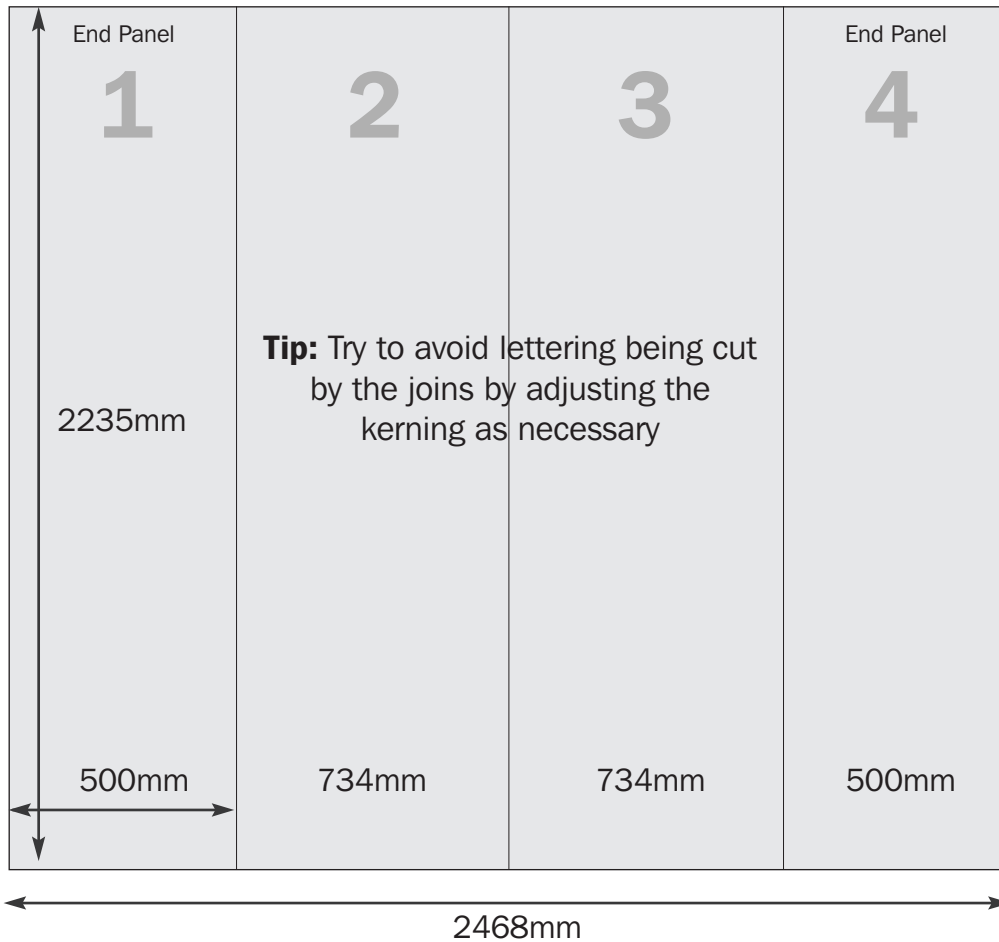

3x2 Graphic Dimensions

Overall artwork size:

2235 x 2468mm

All images **150dpi at finished size**

Quarter size document:

558.75 x 617mm

All images **600dpi at quarter size**

offsite digital

Unit 5, Bolding Hatch Farm Business Centre
Bishops Stortford Road, Roxwell, Chelmsford, Essex CM1 4LF

Telephone: +44 (0)1245 231900 Facsimile: +44 (0)1245 231911
email: sales@offsitigroup.net www.offsite.digital.co.uk

3x3 Pop-Up System (Straight Specification)



Our preferred format for receiving artwork is as high resolution PDF file with all fonts embedded. If you are unable to supply a PDF please look at the Supplying Files on our website.

We suggest that artwork is originated at quarter size - see details below for size specifications

In order to produce an acceptable halftone result on the final output it is recommended that any pictures (bitmaps, jpg, tif etc.) are **at least 150dpi at finished size**. Therefore if you are working at **quarter size any pictures should be 600dpi**. Failure to observe this rule could lead to disappointing results.

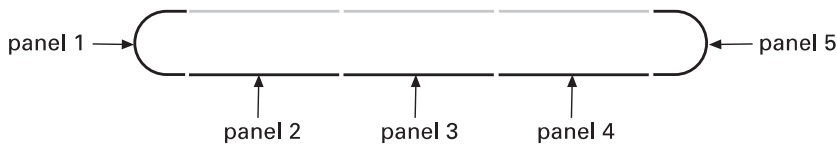
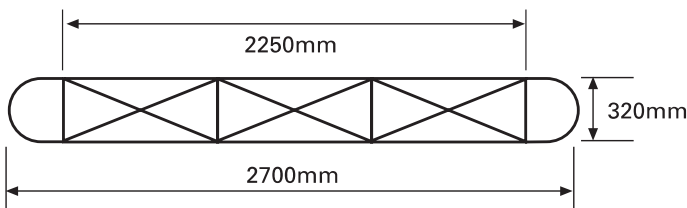
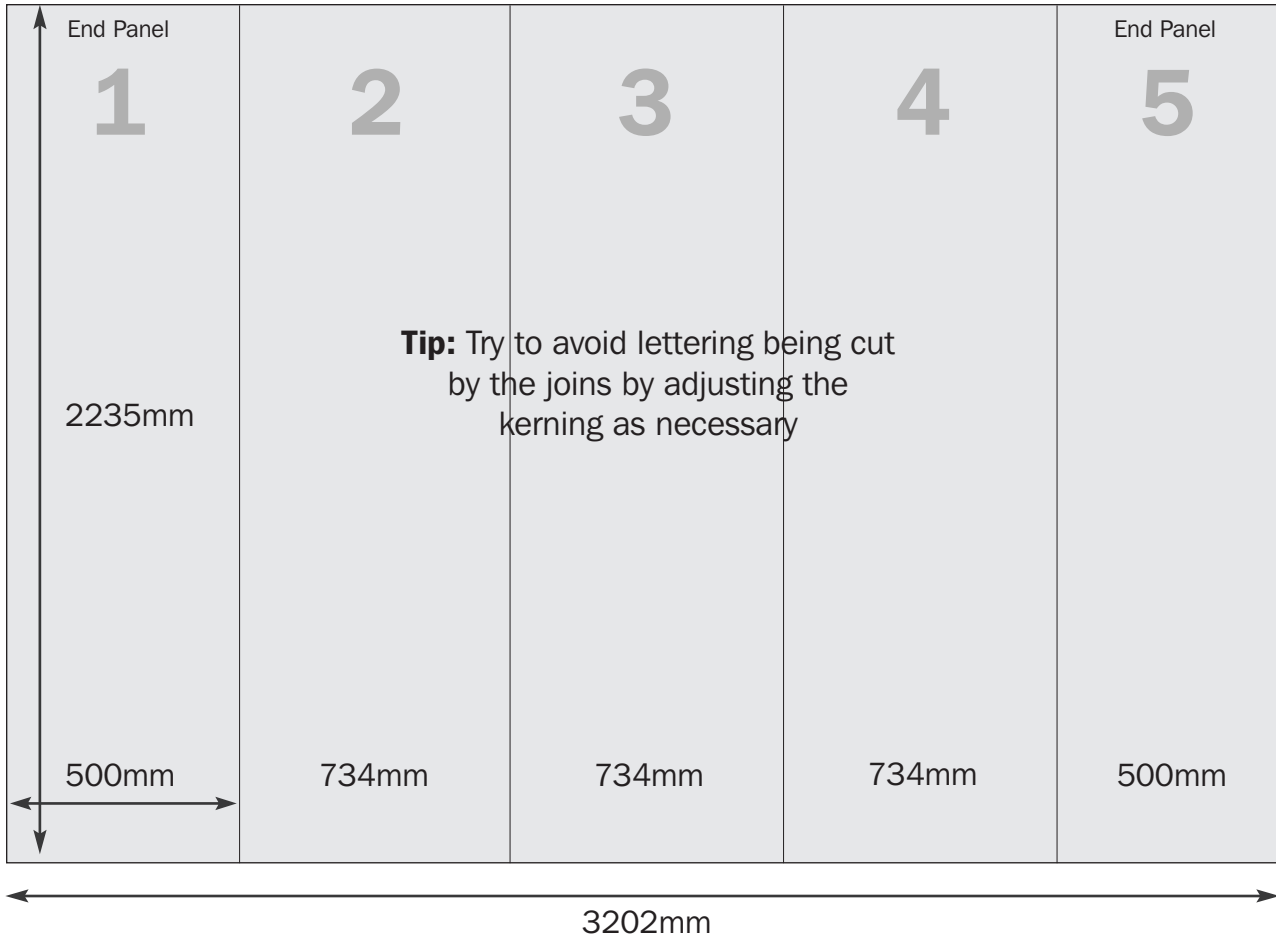

3x3 Graphic Dimensions

Overall artwork size:
2235 x 3202mm
All images **150dpi at finished size**

Quarter size document:
558.75 x 800.5mm
All images **600dpi at quarter size**

3x4 Pop-Up System (Straight Specification)



Our preferred format for receiving artwork is as high resolution PDF file with all fonts embedded. If you are unable to supply a PDF please look at the Supplying Files on our website.

We suggest that artwork is originated at quarter size - see details below for size specifications

In order to produce an acceptable halftone result on the final output it is recommended that any pictures (bitmaps, jpg, tif etc.) are **at least 150dpi at finished size**. Therefore if you are working at **quarter size any pictures should be 600dpi**. Failure to observe this rule could lead to disappointing results.

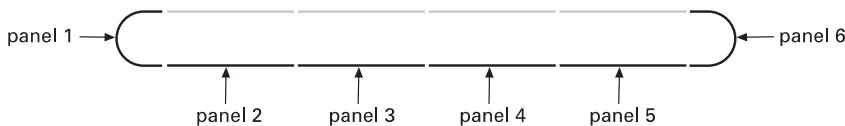
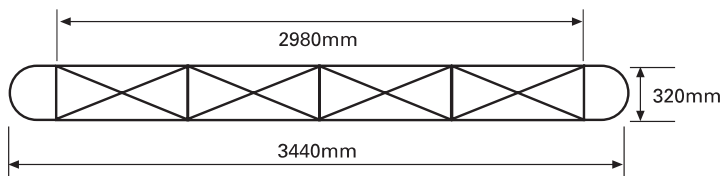
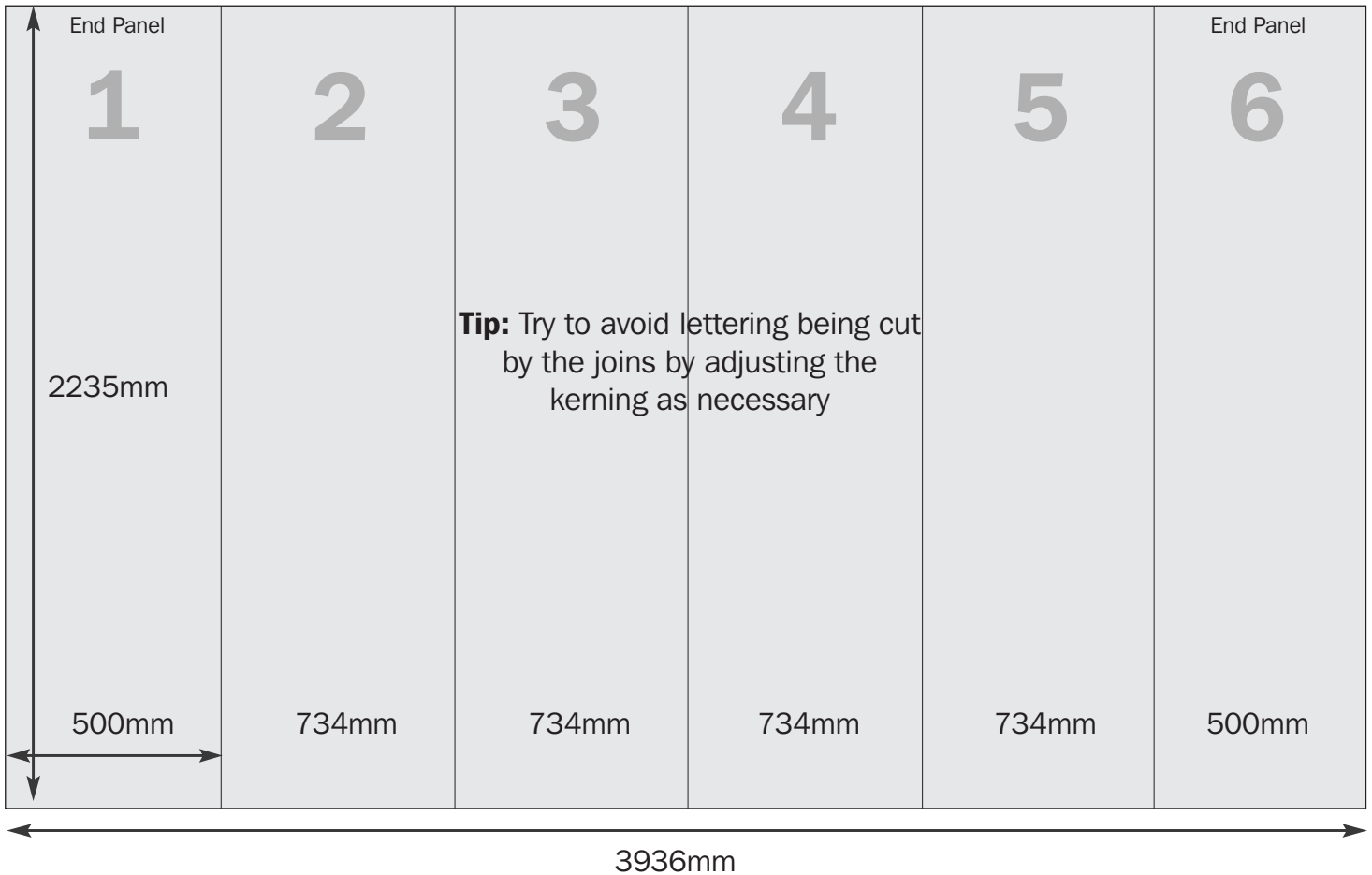

3x4 Graphic Dimensions

Overall artwork size:

2235 x 3936mm

All images **150dpi at finished size**

Quarter size document:

558.75 x 984mm

All images **600dpi at quarter size**

offsite digital

Unit 5, Bolding Hatch Farm Business Centre
Bishops Stortford Road, Roxwell, Chelmsford, Essex CM1 4LF

Telephone: +44 (0)1245 231900 Facsimile: +44 (0)1245 231911
email: sales@offsitigroup.net www.offsitegroup.co.uk